

ELVEDI CANTILEVER RACKING – SIMPLE, SAFE AND STURDY



- ELVEDI has been developing and producing storage technology systems since 1984, which impress with their functionality and quality to the smallest detail.
- Our systems are sturdy and durable. They are produced from top quality materials with certificate of origin and are able to withstand maximum load even after decades.
- The ELVEDI seal provides you with an after-sales guarantee even after years for all rack components.



CANTILEVER RACKING

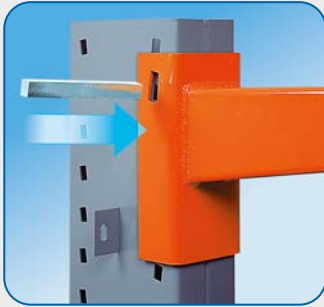

The patented plug-in bolt system only from ELVEDI. Cantilever arm and column are secured and simply connected in a grid of 76 mm by a pin of hardened steel.

The latest production machines guarantee suspended heights for the rack columns true to size.



The ELVEDI cantilever racking is produced as components. The result is very easy assembly with extension options for many years.



The high-quality hammer-stroke epoxy polyester powder coating ensures durable surface protection of the shelves. Only lead-free, organic and water soluble powders are used.

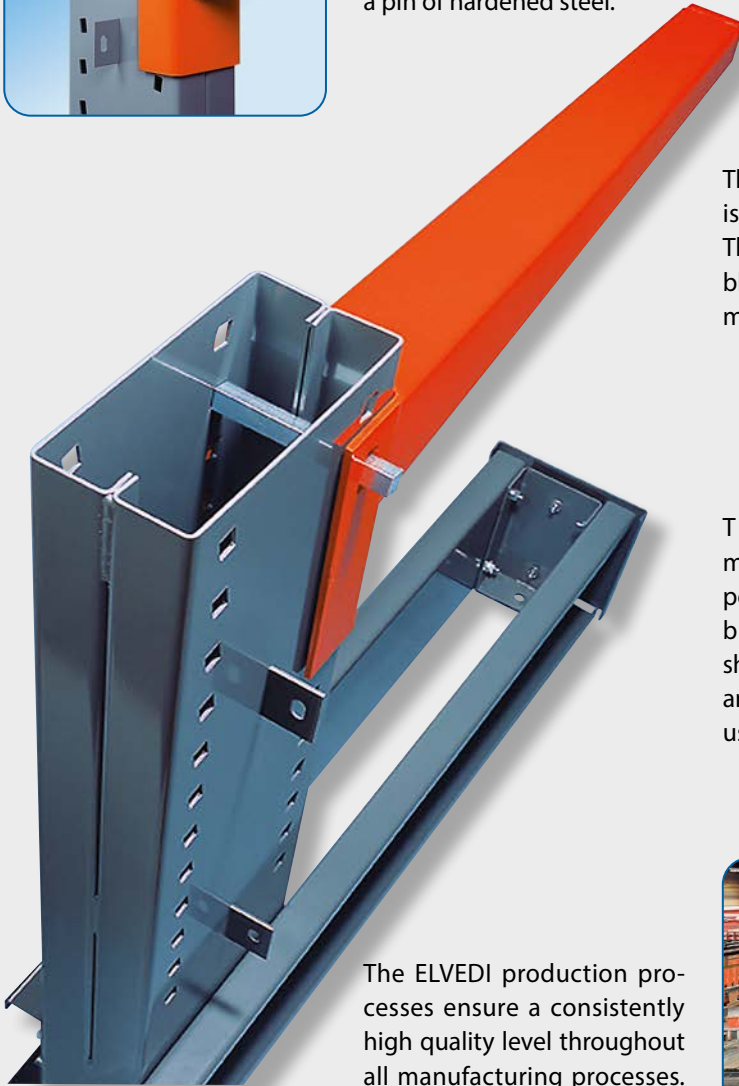

The ELVEDI production processes ensure a consistently high quality level throughout all manufacturing processes.



ELVEDI production facility of the cantilever racking in Blumberg (Black Forest). All products are "Made in Germany" exclusively

YOU HAVE THE STORAGE TASK - WE HAVE THE SUITABLE RACK CONCEPT FOR YOU!

Our ELVEDI cantilever racking has been developed from day-to-day practice.

We meet the most diverse requirements for storage technology with a broad range of products. Different products to be stored require individual solutions, which we already cover in most cases with our modular variable standard systems.

- Versatile modular system for each type of store room and stored goods
- High-quality powder coating for the inside area
- Durable galvanising for the outside area
- Cantilever racking with roof construction as cold hall
- Shelf systems for light to heaviest loads
- Single-sided and double-sided shelf system
- Cantilever racking with short delivery times
- Cantilever racking with roof and wall

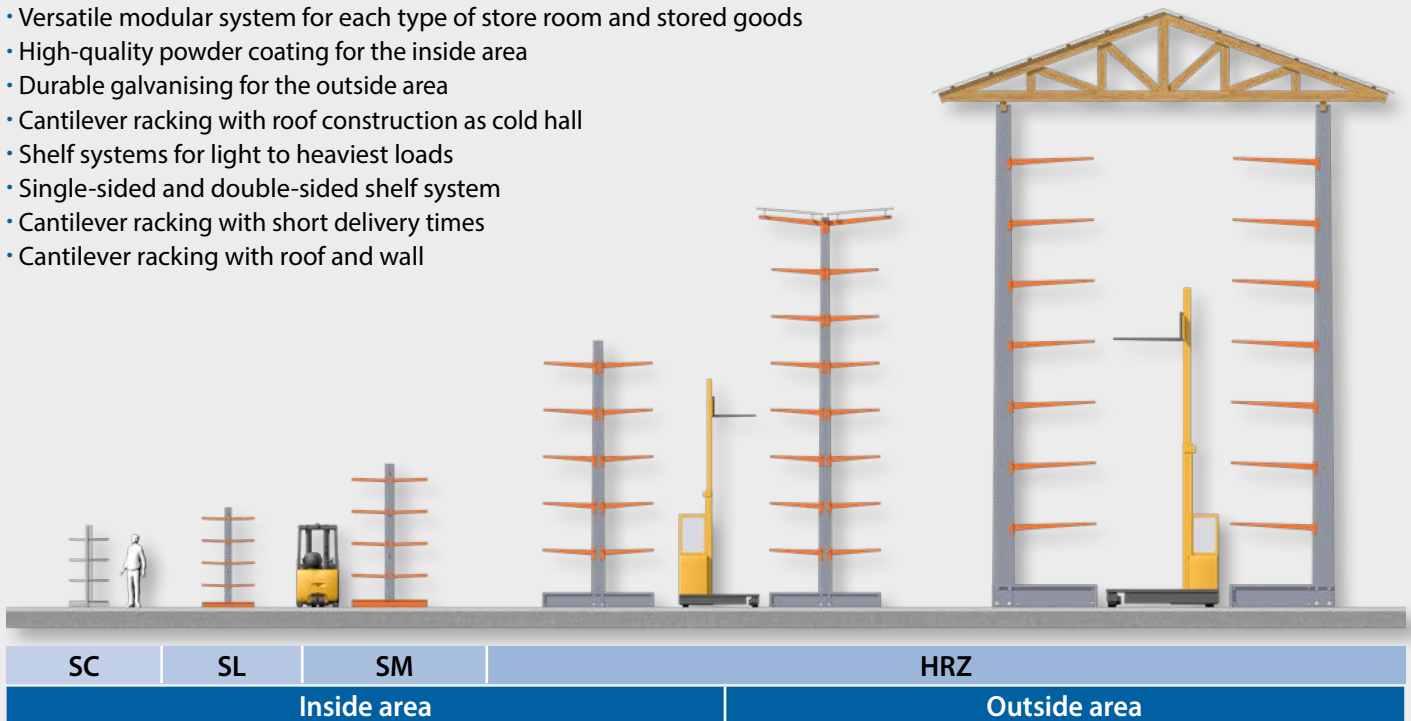

		SC		SL		SM		HRZ	
Usage		light loads		light loads		moderately heavy loads		heavy loads	
Deliverable heights [mm]		2.000		1.976 / 2.432 / 2.964		2.432 / 2.964 / 3.496		1.976 bis 20.000	
Usable depth [mm]	Carrying capacity per support arm [kg]	400	170	500	300	600	500	600 bis	500 bis
		600	110	700	200	800	400	2.500	3.650
Installation site		inside		inside		inside		inside / outside	
Version		single-sided / double-sided		single-sided / double-sided		single-sided / double-sided		single-sided / double-sided	
Delivery times		Delivery 7 days from factory / goods in stock		Delivery 7 days from factory / goods in stock		Delivery 7 days from factory / goods in stock		Order-related production / delivery 4-6 weeks ex works	

CANTILEVER RACKING SC - SL

Goods in stock
7 days ex factory

CANTILEVER RACKING SC



The ELVEDI cantilever racking type SC is being used wherever small parts need to be organised into clearly arranged, instantly accessible, efficient stock keeping.

In each factory, with every craftsman, a standardised, light system shelf ex works.

Support arms

- Two punch holes in the centre and at the arm ends for receiving optional divisions or end stops
- Usable depth [mm] / carrying capacity [kg]: 400/170, 600/110



Base

- By default with two punch holes in the centre and at the front side for receiving optional divisions or end stops



Cranked support arms

- For the ring gut bearing (extension cable, V-belt or similar)



Shelves

- For workshop inventory like paint buckets, cartons, cable drums
- Small parts shelf level
- Usable depth [mm] / carrying capacity [kg]: 400/170, 600/110

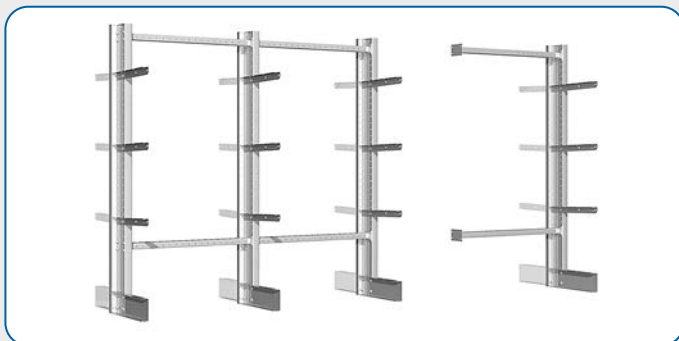

Base and add-on module, single-sided and double-sided

Height	[mm]	2,000
---------------	------	-------

Single-sided		Basic module		Add-on module	
Shelf length	[mm]	1,050	1,300	1,050	1,300
Usable depth	[mm]	400	600	400	600
Carrying capacity level)1	[kg]	510	330	170	110
Total carrying capacity)1)2	[kg]	2,040	1,320	680	440

Double-sided		Basic module		Add-on module	
Shelf length	[mm]	1,050	1,300	1,050	1,300
Usable depth	[mm]	400	600	400	600
Carrying capacity level)1	[kg]	510	330	170	110
Total carrying capacity)1)2	[kg]	4,080	2,640	1,360	880

)1 For levels with shelves the load capacity reduces

)2 Total carrying capacity [kg] = plus base

YOUR ADVANTAGE: VERSATILITY

CANTILEVER RACKING SL

Goods in stock
7 days ex factory



The light and adaptable ELVEDI cantilever racking type SL is designed specifically for companies which work with long goods like pipes, bars, sheet metals, beams, plane goods etc.

- Trouble-free rack retrofitting from single-sided to double-sided version or vice versa - thanks to screw connection rack column/ base.
- The proven ELVEDI plug connection enables a height adjustment of the support arms in the grid dimension of 76 mm independent of the side.
- Column distance (dimension between axes) in different lengths for needs-based load distribution.
- Intersections possible in 1,000mm / 1,200mm / 1,500mm.
- Support arms punched 2-fold by default for subsequent attachment of screwed partitioning and end stops.
- Standard 2-fold punching on the base for receiving the unroll locks.
- Column / sendzimir-galvanised, support arms and base Epoxy polyester powder-coated orange RAL 2004.

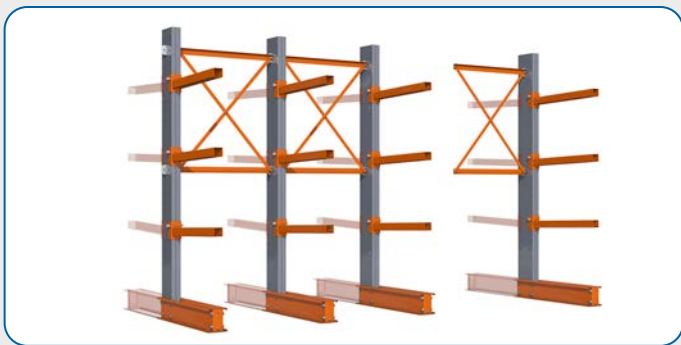

Grund und Anbaumodul, einseitig und doppelseitig

Height	[mm]	1,976 / 2,432 / 2,964			
--------	------	-----------------------	--	--	--

Single-sided		Basic module		Add-on module	
Shelf length	[mm]	1,180		1,000	
Usable depth	[mm]	500	700	500	700
Carrying capacity level	[kg]	900	600	300	200
Total carrying capacity *	[kg]	4,500	3,000	1,500	1,000

Double-sided		Basic module		Add-on module	
Shelf length	[mm]	1,180		1,000	
Usable depth	[mm]	500	700	500	700
Carrying capacity level	[kg]	900	600	300	200
Total carrying capacity *	[kg]	9,000	6,000	3,000	2,000

*Total carrying capacity [kg] = plus base

ACCESSORIES



Base



Support arm

CANTILEVER RACKING SM

Goods in stock
7 days ex factory

CANTILEVER RACKING SM



Order and clarity in your long goods warehouse with the elegant ELVEDI cantilever racking type.

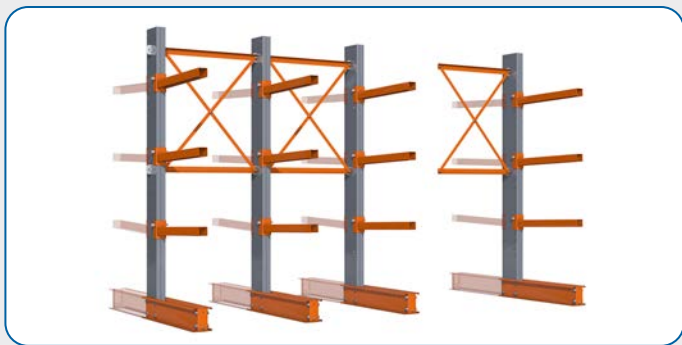

Base and add-on module, single-sided and double-sided

- Versatile modular system for individual adaptation to each type of store room and stored goods.
- Impressive standard construction for single-sided and double-sided use without wall and ceiling mounting.
- The proven ELVEDI plug connection enables a height adjustment of the support arms in the grid dimension of 76 mm independent of the side.
- Environmentally-friendly technology. Disassembled and packed for low freight volume.
- Intersections possible in 1,000mm / 1,200mm / 1,500mm.
- 3-fold punching of support arms, special storage capacity for pipes with small diameter (sanitary purposes).
- Standard unroll lock on the base.
- column/senzimir-galvanized, support arms and base Epoxy polyester powder-coated orange RAL 2004.

Höhen	[mm]	2,432 / 2,964 / 3,496
-------	------	-----------------------

Single-sided	Basic module			Add-on module			
	Shelf length	[mm]	1,160			1,000	
Usable depth	[mm]	600	800	1,000	600	800	1,000
Carrying capacity level	[kg]	1,500	1,200	900	500	400	300
Total carrying capacity*	[kg]	6,000	4,800	4,200	2,000	1,600	1,400

Double-sided	Basic module			Add-on module			
	Shelf length	[mm]	1,160			1,000	
Usable depth	[mm]	600	800	1,000	600	800	1,000
Carrying capacity level	[kg]	1,500	1,200	900	500	400	300
Total carrying capacity*	[kg]	12,000	9,800	8,400	4,000	3,200	2,800

*Total carrying capacity [kg] = plus base

ACCESSORIES



Base



Support arm

MAXIMUM VARIABILITY – FOR CHANGING REQUIREMENTS

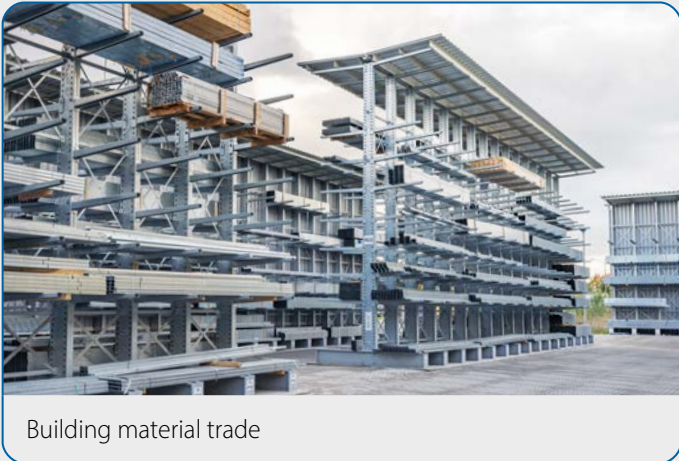

Building material trade

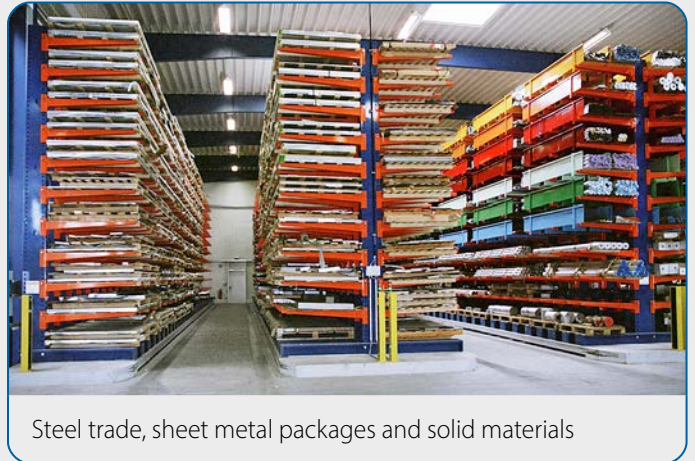

Steel trade, sheet metal packages and solid materials

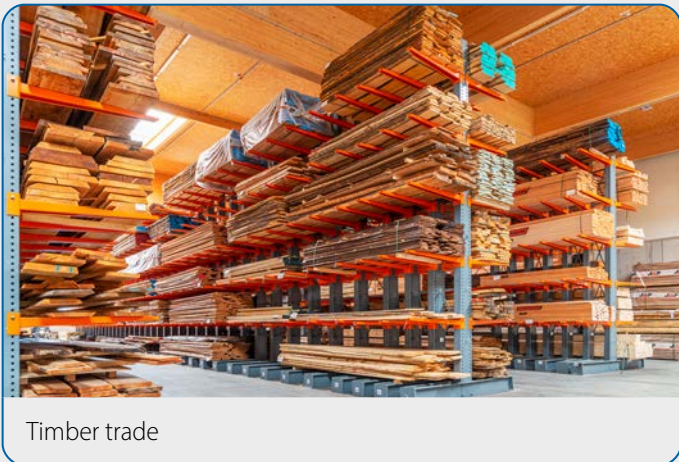

Timber trade

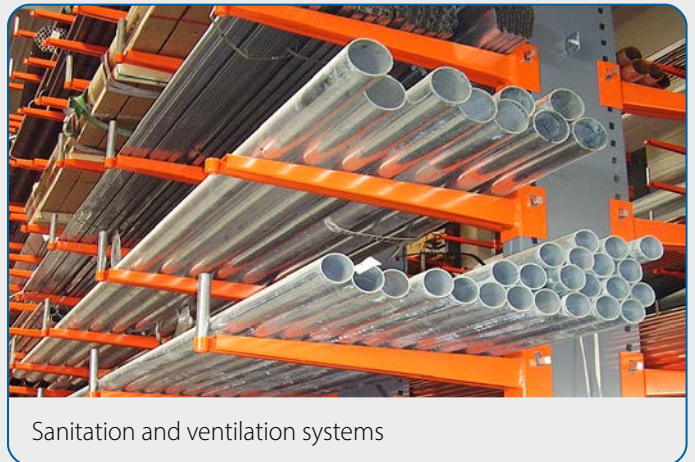

Sanitation and ventilation systems

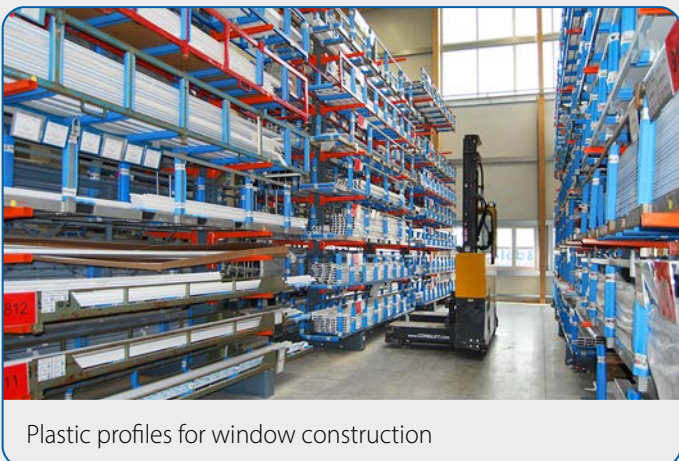

Plastic profiles for window construction

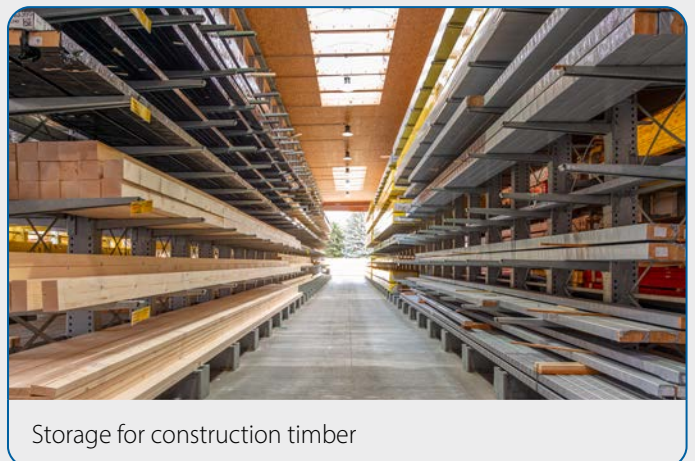

Storage for construction timber

CANTILEVER RACKS HRZ



SIMPLE, SAFE AND STURDY: ELVEDI HRZ CANTILEVER RACKS

The product line of the ELVEDI cantilever racks is available for fast storage and removal of stored goods of various lengths and shapes.

ELVEDI standards for your safety:

All components of the system solution are produced from high-quality steel and can still be delivered many years later. All systems are calculated statically separately, as different load torques occur in every system. The static basics have been validated by independent testing institutes. ELVEDI racking meets all important legal requirements and guidelines across Europe in Euro-Code 3. HRZ rack columns have a slightly tilted perforated grid, enabling a direct, form-locking connection of the arm-column-link. With the simple one-bolt-technology (plug pin of specially hardened steel) without positioning obligation, many

different application options are available. Later rehangng of the support arms is extremely simplified. The patented screw connection between the column and the base enables cost-effective and fast retrofitting from single-sided to double-sided columns.

Long service life:

Depending on the application, the rack systems can be produced as **galvanised or powder-coated version**. Galvanised screw material and bolts are used as standard. Useful accessories like edge protection (incl. unroll lock), crossbeams and guide rails ensure long preservation of value and service life of the rack system.

BASED ON EXISTING SYSTEM DESIGNS

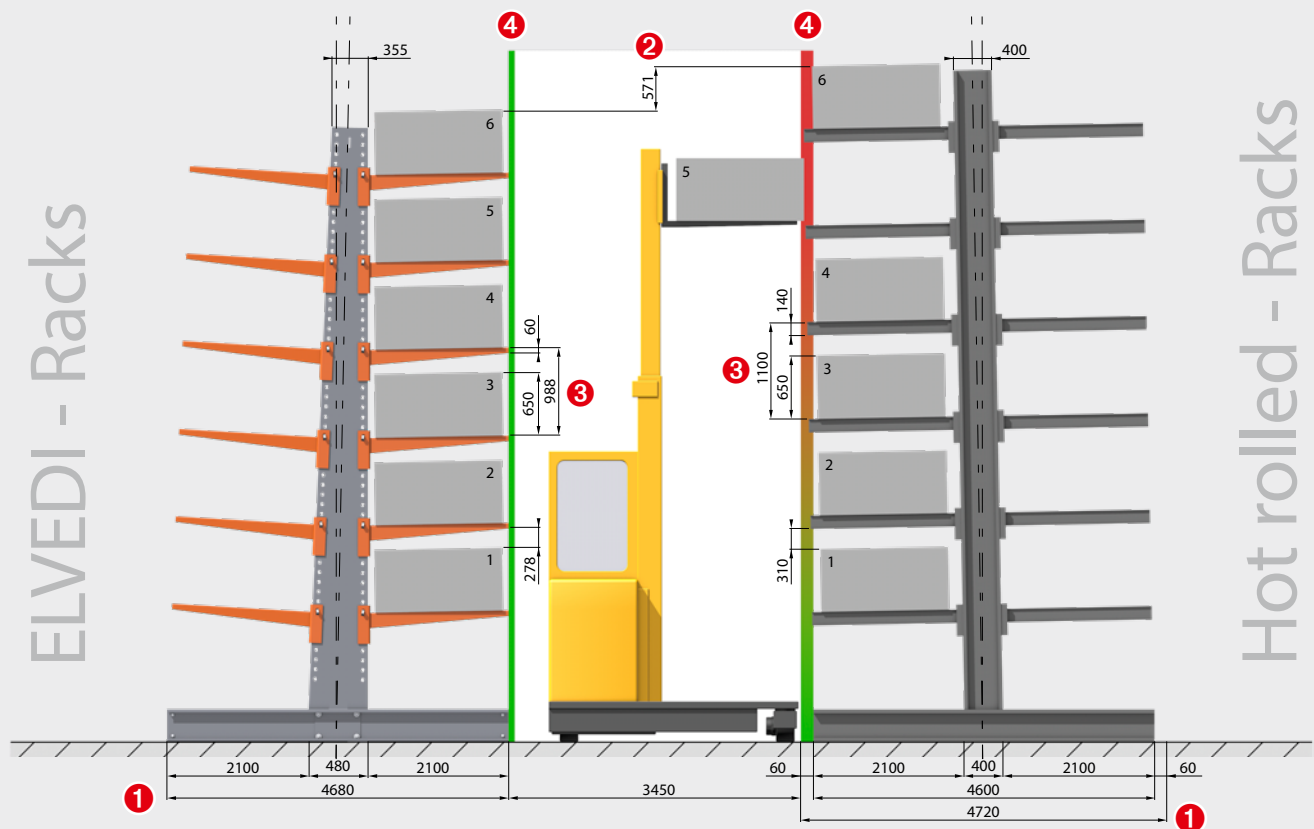

1 ELVEDI achieves lower shelf depths through conicity and rigid frame of the columns with multiple edges. With hot rolled sections the columns tilt from approx. 4 m height - the special property of steel. This increases the total depth of the rack by 120 mm (see 4 green/red line).

2 Better usage of room height - more shelves with the finer ELVEDI grid dimension of 76mm.

3 Larger optical shelf height with 200mm spoil play. (Forklift driver)

4 Even in case of unfavourable load distribution (only single-sided with maximum load), with ELVEDI there are no support arms protruding into the aisle (see red/green line). With hot rolled racks, the upper shelves are damaged by the reduced aisle width.

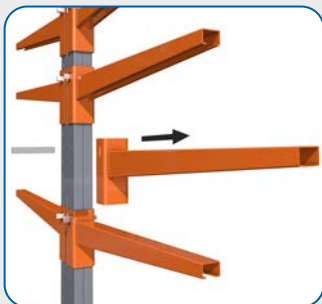

Patented plug bolt system. Support arms removable in parallel.

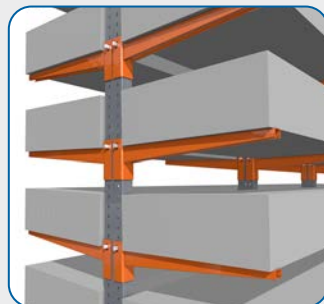

Optically larger shelf heights due to tapered support arms.

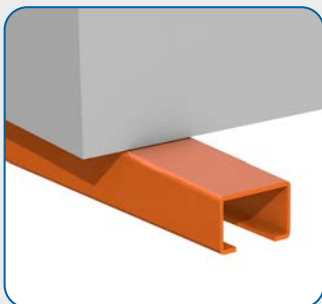

Gentle storage. No damage due to rounded off edges.

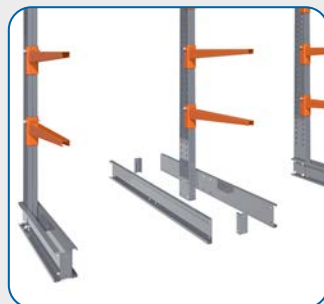

Simple retrofitting from single-sided to double-sided shelves.

TECHNICAL DATA HRZ

The rack type HRZ is built for heavy and extremely heavy loads. Especially dimensioned according to your desires and requirements, this rack type can be used as high storage and complete system as well as roof- or wall-supported hall construction.

Usable depth support arm	600 - 2,500 mm,
Carrying capacity per support arm	500 - 3,650 kg,
Column height	1,976 - 18,000 mm,
Column load capacity per side	2,000 - 20,000 kg,
Column design	single-sided / double-sided
Dimension between axes (standard)	500 - 3,500 mm,
End stop pluggable	100 / 150 / 200 / 250 mm,
Height adjustment	every 76 mm

- Rack columns, bases and connections, epoxy polyester powder-coated grey (RAL 7031)
- Support arms, epoxy polyester powder-coated orange (RAL 2004)
- End stops galvanised
- For the outside area, the rack system is delivered with hot dip galvanizing

CANTILEVER RACKS HRZ

ELVEDI PROVIDES YOU WITH INDIVIDUAL



Edge protection

Optimum protection from damage of your goods when storing and removing.

Unroll lock

Prevents round materials from falling down. The unroll lock contributes to the best possible occupational safety.

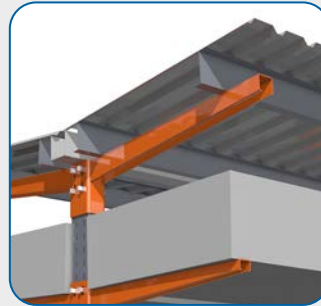

Roof arm

Roof arms with Z-profiles and trapezoidal sheets protect the goods from weather influences. Roof arms at different lengths, can be delivered inclined upwards and downwards. Optionally with drainpipes and downpipes.

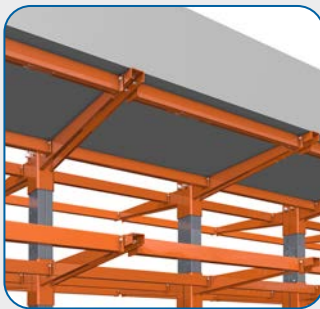

Cross-beam

„Endless storage“ without lateral and sectional divisions provides a significant increase in storage space.

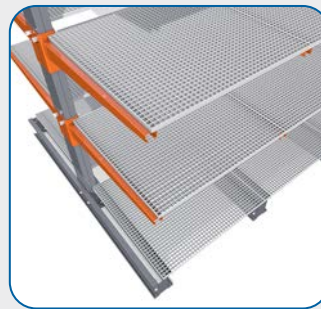

Grates

Infinite storage of goods with different depth and width. Grates are also used when using sprinkler systems (permeable to water).



Crush zone

The effective ram protection absorbs impact forces upon collision of the fork lift. It prevents damage to the rack and stored goods.

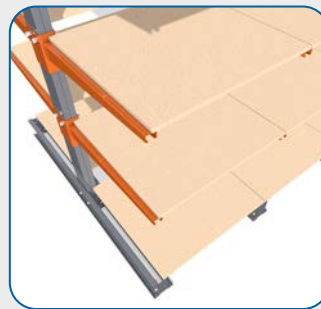

Chipboards

In addition to grates, the variation with chipboards that's where they come in. They are used when the stored goods are not too heavy.



Socket for end stop on base

For long goods like PVC pipes, copper pipes as well as plastic and aluminium profiles.

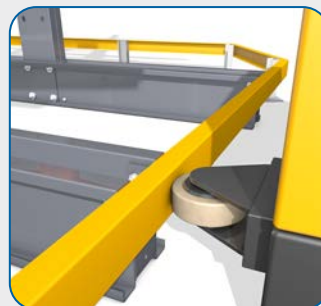

Guide rails

Rail-guided fork lifts enable optimisation of the aisle widths. The entrance here is provided with a funnel.

ELVEDI PROVIDES YOU WITH INDIVIDUAL



COLD HALLS WITH CANTILEVER SYSTEM PROFILES:
SIMPLY ROOFED OVER CANTILEVER RACKS WITH
ROOF AND WALL



Cantilever rack as timber store with roof



Cantilever rack as timber and building material store with roof and wall cover

ELVEDI SUBSIDIARIES CAN BE FOUND THROUGHOUT EUROPE

...

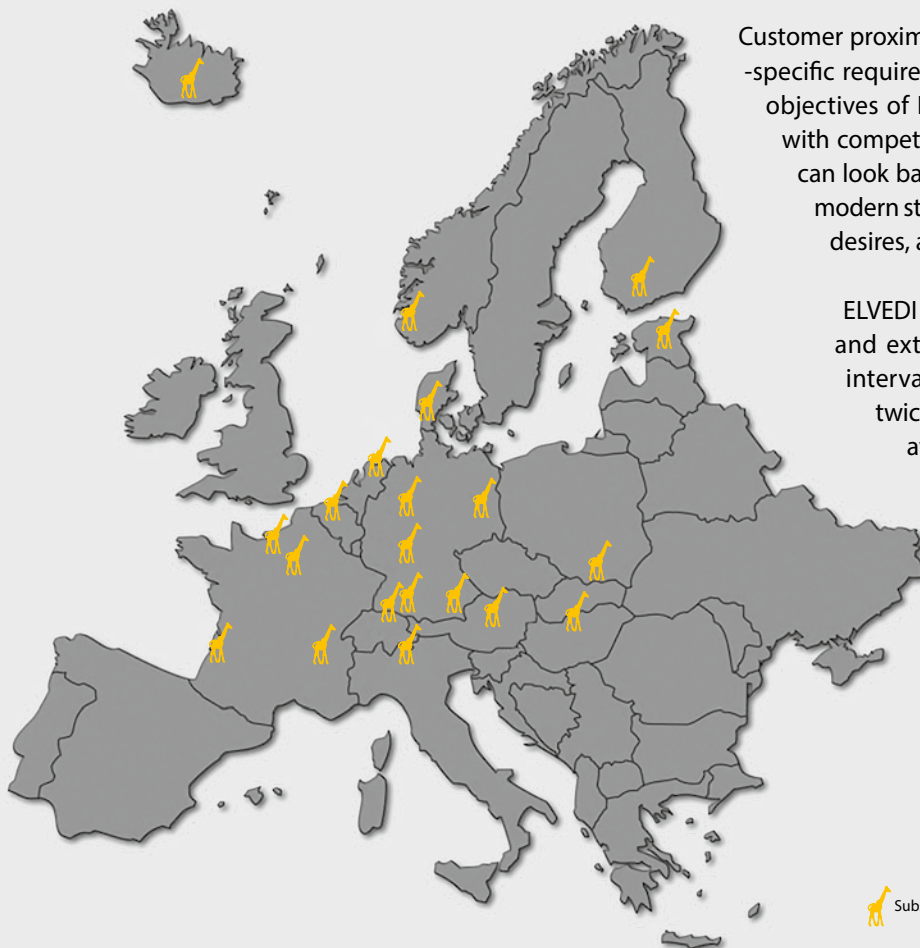

 Subsidiary / Regional Office

Customer proximity and best possible meeting of the industry-specific requirements of each industry are the predominant objectives of ELVEDI. Our subsidiaries and regional offices with competent consultants and planning engineers, who can look back on many years of experience in the area of modern storage solutions and are open to your individual desires, are available to you throughout Europe.

ELVEDI will notify you of new product developments and extensions of your system solutions at regular intervals in the ELVEDI newsletter being published twice a year. We keep you up to date and are always available to you on our trilingual website, which is based on a modern Intranet.

Of course you will also find contact partners of the ELVEDI Group at all important European trade fairs.

... AND CERTAINLY NEAR YOU AT LEAST ONCE

ELVEDI GmbH

Aitlingerstrasse 18
D-78176 Blumberg

Phone +49 (0)7702 4382 0
Fax +49 (0)7702 4382 10
info@elvedi.com

Mandatory annual inspections for warehouse equipment according to DIN EN 15635



Racks and shelves are work equipment. The European standard DIN EN 15635 defines the inspection procedure for storage equipment/racking.

